



Technical Data

PARTITION-MOUNTED SANITARY NAPKIN DISPOSAL

(SERVES TWO TOILET COMPARTMENTS)

B-354

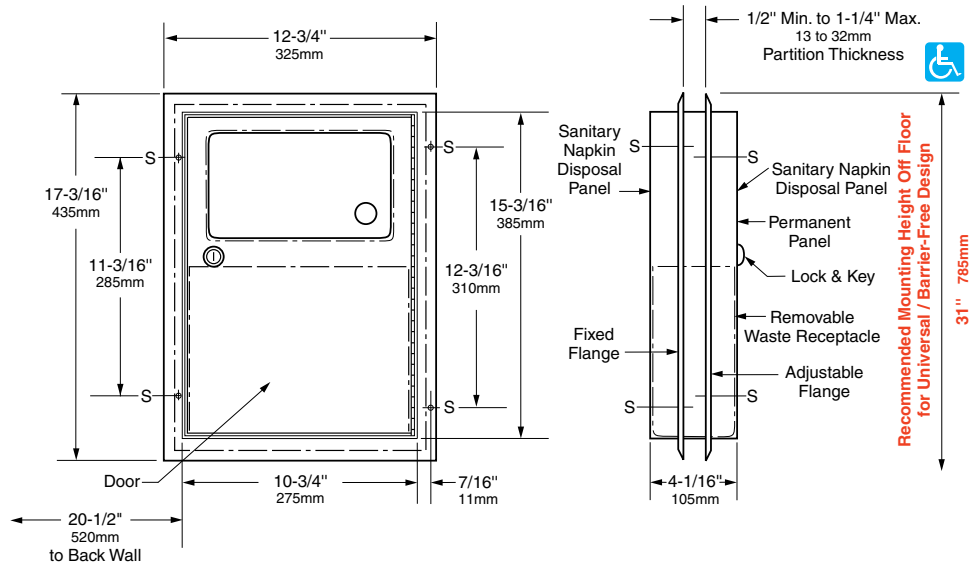

Rough Partition Cutout
 11" (280mm) wide
 15-1/2" (395mm) high
 1/2" to 1-1/4" (13 to 32mm)
 partition thickness

MATERIALS:

Cabinet — 18-8 S, type-304, heavy-gauge stainless steel. All-welded construction. Exposed surfaces have satin finish.

Flanges (2) — 18-8 S, type-304, 22-gauge (0.8mm) stainless steel with satin finish. Drawn and beveled, one-piece, seamless construction.

Door — 18-8 S, type-304, 22-gauge (0.8mm) stainless steel with satin finish. Secured to cabinet with a full-length stainless steel piano-hinge. Equipped with a tumbler lock keyed like other Bobrick washroom accessories.

Disposal Panels (2) — 18-8 S, type-304, 22-gauge (0.8mm) stainless steel with satin finish. Bottom edges hemmed for safety. Secured to door and permanent panel with spring-loaded, full-length stainless steel piano-hinges. Equipped with international graphic symbols identifying sanitary napkin disposal.

Waste Receptacle — Leak-proof, rigid molded polyethylene. Removable for servicing. Capacity: 1.2-gal. (4.6-L).

OPERATION:

Unit is equipped with a self-closing panel covering each disposal opening. Napkin disposal is emptied by opening door with furnished key and removing waste receptacle. Disposable paper liners for the receptacle are available as an optional accessory: order Bobrick Part No. 353-12.

continued . . .

INSTALLATION:

Mounts in toilet partition 1/2" to 1-1/4" (13 x 32mm) thick, centered through a cutout specially ordered from partition manufacturer or field cut. Dimensions of cutout are to be 11" wide x 15-1/2" high (280 x 395mm). For factory-made cutouts, location and size details should be furnished to partition manufacturer. For hollow-core metal partitions, solid framing into which mounting sheet-metal screws can be secured is required.

For installation with sheet-metal screws furnished, place unit firmly in partition opening, making sure the entire perimeter of fixed flange is tight against partition surface, then secure to partition with sheet-metal screws furnished, through four holes in fixed flange at points indicated by an S. On other side of partition, position adjustable flange so the mounting screw holes are not inline with mounting screw holes in fixed flange. Make sure the entire perimeter of adjustable flange is tight against partition surface, then secure with sheet-metal screws furnished.

For through-bolting method of installation, make sure that mounting holes in adjustable flange are inline with holes in fixed flange. Using adjustable flange as template for locating centers, drill 7/32" or 1/4" (5.5 or 6.4mm) holes through partition. Provide four binder post and #6 (3.5mm) flat-head sheet-metal screws to secure unit and its adjustable flange. Obtain binder posts and sheet-metal screws by ordering Bobrick Binder Post Kit No. 354-119 for partitions 1/2" (13mm) thick or Kit No. 354-124 for partitions 3/4" to 1-1/4" (19 to 32mm) thick.

Designer's Note: Cutouts in Bobrick toilet partitions can be pre-cut for Bobrick partition-mounted accessories at factory if location and size of cutouts are specified and the order for both partitions and accessories are received together.

SPECIFICATION:

Partition-mounted sanitary napkin disposal shall be type-304 stainless steel with all-welded construction; exposed surfaces shall have satin finish. Flanges shall be drawn and beveled, one-piece seamless construction. Unit shall mount in partition and serve two toilet compartments. Door shall be secured to cabinet with a full-length stainless steel piano-hinge and equipped with a tumbler lock keyed like other Bobrick washroom accessories. Unit shall have a self-closing panel covering each disposal opening. Panels shall have bottom edges hemmed for safety, be secured to door with spring-loaded, full-length stainless steel piano-hinges, and equipped with international graphic symbols identifying sanitary napkin disposal. Unit shall be furnished with a removable, leak-proof molded polyethylene receptacle. Receptacle shall have a capacity of 1.2-gal. (4.6-L). Manufacturer's service and parts manual shall be provided to the building owner/manager upon request.



RYNAT INDUSTRIES AUSTRALIA PTY LTD | www.rynat.com | Email: sales@rynat.com |
| Aust Wide: 1300 558 518 | Tel: +61 8 6254 6555 | 20 Murray Rd South Welshpool WA |