

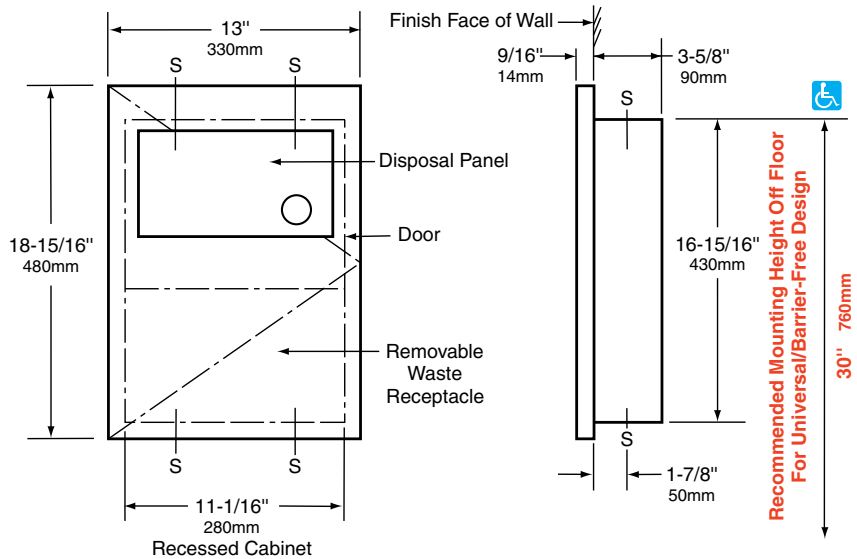

Technical Data

RECESSED SANITARY NAPKIN DISPOSAL

B-35303



Rough Wall Opening
 11-1/2" (290mm) wide
 17-1/4" (440mm) high
 3-3/4" (95mm) minimum
 recessed depth

MATERIALS:

Cabinet — 18-8 S, type-304, stainless steel. All-welded construction.

Door — 18-8 S, type-304, 18-gauge (1.2mm) stainless steel with satin finish. 9/16" (14mm) 90° return for maximum rigidity. Secured to cabinet with a concealed, full-length stainless steel piano-hinge.

Disposal Panel — 18-8 S, type-304, 22-gauge (0.8mm) stainless steel with satin finish. Secured to door with a concealed, full-length stainless steel piano-hinge. Self-closing panel has international graphic symbol identifying napkin disposal.

Waste Receptacle — Leak-proof rigid molded polyethylene. Removable for servicing. Capacity: 1.2-gal. (4.6-L).

OPERATION:

Unit is equipped with self-closing panel covering disposal opening. Napkin disposal is emptied by opening door and removing waste receptacle. Disposable paper liners for napkin receptacle are available as optional accessory: order Bobrick Part No. 353-12.

INSTALLATION:

Provide framed rough wall opening 11-1/2" wide x 17-1/4" high (290 x 440mm). Minimum recessed depth required to finish face of wall is 3-3/4" (95mm). Allow for construction features that may protrude into rough wall opening from opposite wall. Coordinate with mechanical engineer to avoid pipes, vents, and conduits. If unit projects above top of wainscot, provide aluminum channel or other filler to eliminate gap between flange and finish face of wall. Mount unit in wall opening with shims between framing and cabinet at all points indicated by an S, then secure unit with #8 x 1-1/4" (4.2 x 32mm) sheet-metal screws (not furnished).

SPECIFICATION:

Recessed sanitary napkin disposal shall be type-304 stainless steel with all-welded construction; exposed surfaces shall have satin finish. Door shall have 9/16" (14mm) 90° return and be equipped with a concealed, full-length stainless steel piano-hinge. Napkin disposal shall have self-closing stainless steel panel covering receptacle opening. Panel shall be equipped with full-length stainless steel piano-hinge and international graphic symbol identifying napkin disposal. Unit shall be furnished with a removable, leakproof, molded polyethylene receptacle. Receptacle shall have a capacity of 1.2-gal. (4.6-L). Manufacturer's service and parts manual shall be provided to the building owner/manager upon request.



RYNAT INDUSTRIES AUSTRALIA PTY LTD | www.rynat.com | Email: sales@rynat.com |

| Aust Wide: 1300 558 518 | Tel: +61 8 6254 6555 | 20 Murray Rd South Welshpool WA |