

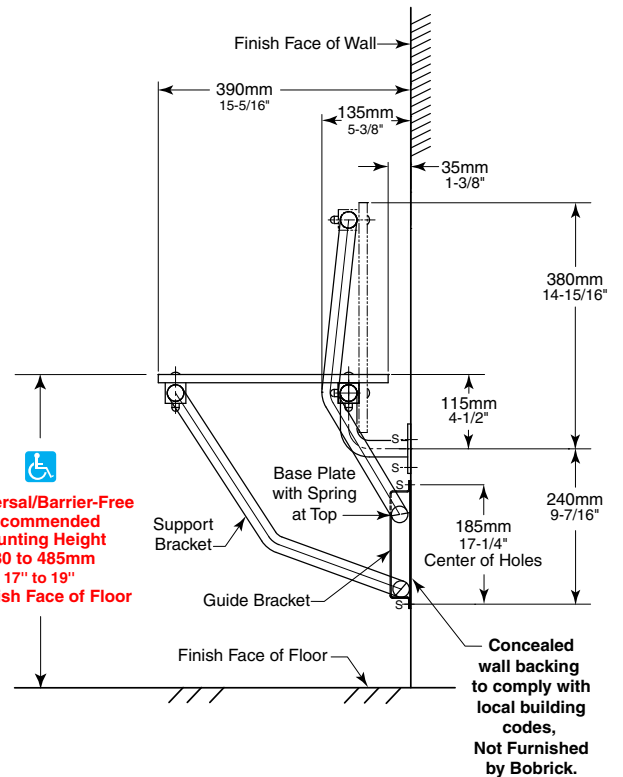

Technical Data

# AS1428.1 PHENOLIC SHOWER/DRESSING AREA SEAT

# 819687

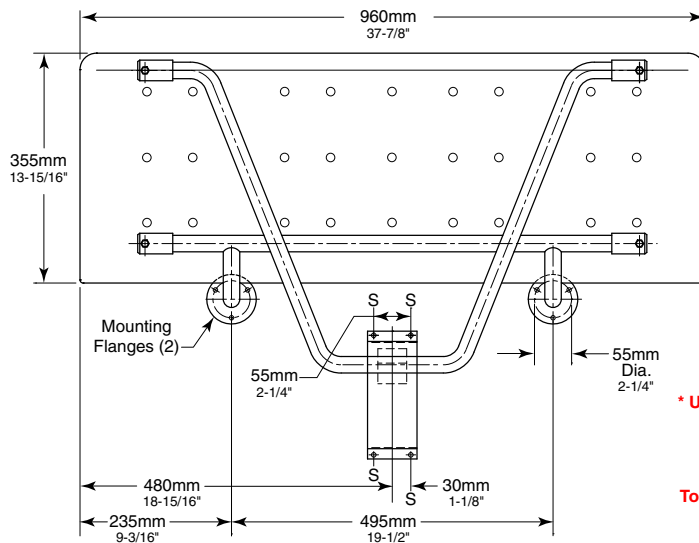

 **\* Universal/Barrier-Free Recommended Mounting Height 430 to 485mm 17" to 19" To Finish Face of Floor**

\*Consult local building codes

## MATERIALS:

**Seat** — One-piece, 1/2" (13mm) thick, solidly fused plastic laminate with matte-finish melamine surfaces, ivory-colored face sheets, and black phenolic-resin core that are integrally bonded — cannot delaminate. Integral holes for water drainage. Secured to frame with stainless steel carriage bolts and acorn nuts.

**Frame** — 18-8 S, type-304, stainless steel with satin finish. 1.6mm (16-gauge), 30mm (1-1/4") square tubing and 1.2mm (18-gauge), 25mm (1") diameter seamless tubing.

**Mounting Flanges (2)** — 18-8 S, type-304, 5mm (3/16) thick stainless steel with satin finish. 75mm (3") diameter with three mounting screw holes.

**Baseplate** — 18-8 S, type-304, heavy-gauge stainless steel.

**Spring** — 17-7, type-301, 0.6mm (24-gauge) stainless steel. Spot-welded to baseplate.

**Guide Bracket** — 18-8 S, type-304, 1.6mm (16-gauge) stainless steel with satin finish.

continued . . .



## OPERATION:

Shower seat can be folded up against the wall when not in use. The spring at the top of baseplate locks seat into upright position until released by pulling the top of seat away from wall. Support system with guide bracket allows varying mounting heights and leaves floor clear for easier cleaning. Nonporous solid phenolic seat has holes to permit water to drain, does not splinter or require oiling, and will not support growth of bacteria. Slotless round-head carriage bolts and acorn nuts provide additional safety to user. Bobrick shower seats, when properly installed, have sufficient strength to support 227kg, complying with barrier-free accessibility guidelines (including ADAAG in U.S.A.).

## INSTALLATION:

Secure unit to wall partition at points indicated by an S, with the two mounting flanges located at top and the baseplate and guide bracket below. The bottom of support bracket must be positioned between the baseplate and guide bracket before they are secured to wall or partition. Mounting height of shower seat must comply with local building codes.

For stud walls, provide concealed backing to comply with local building codes then secure with M6 x 65mm (#14 x 2-1/2") sheet-metal screws furnished by manufacturer.

For concrete walls, provide fiber plugs or expansion shields for use with screws furnished, or provide 6mm (1/4") toggle bolts or expansion bolts. *Designer's Note:* Bobrick Screw Anchor Kit, Part No. 517-22, is available as an optional accessory; order one Anchor Kit for each shower seat to be installed.

For solid-core shower partitions, provide sheet-metal screws (or through-bolts, nuts, and washers) and concealed backing to comply with local building codes.

*Caution: These shower seats are no stronger than the anchors and walls to which they are attached and, therefore, must be firmly secured in order to support the loads for which they are intended. Consult and comply with local building codes.*

## SPECIFICATION:

Folding shower seat shall have a frame constructed of type-304, satin-finish stainless steel that consists of 1.6mm (16-gauge), 1-1/4" (30mm) square tubing and 1.2mm (18-gauge), 25mm (1") diameter seamless tubing. Seat shall be one-piece, 13mm (1/2") thick, solidly fused plastic laminate with matte-finish melamine surfaces, ivory-colored face sheets, and black phenolic-resin core; secured to frame with stainless steel carriage bolts and acorn nuts. Shower seat shall be equipped with two 75mm (3") diameter mounting flanges constructed of type-304, 5mm (3/16") thick, satin-finish stainless steel; a guide bracket constructed of type-304, 1.6mm (16-gauge), satin-finish stainless steel; and a spring constructed of type-301, 0.6mm (24-gauge) stainless steel that is spot-welded to a baseplate of type-304, heavy-gauge stainless steel. Seat shall be able to lock in upright position when not in use. Shower seat shall comply with barrier-free accessibility guidelines for structural strength.



RYNAT INDUSTRIES AUSTRALIA PTY LTD | [www.rynat.com](http://www.rynat.com) | Email: [sales@rynat.com](mailto:sales@rynat.com) |  
| Aust Wide: 1300 558 518 | Tel: +61 8 6254 6555 | 20 Murray Rd South Welshpool WA |