

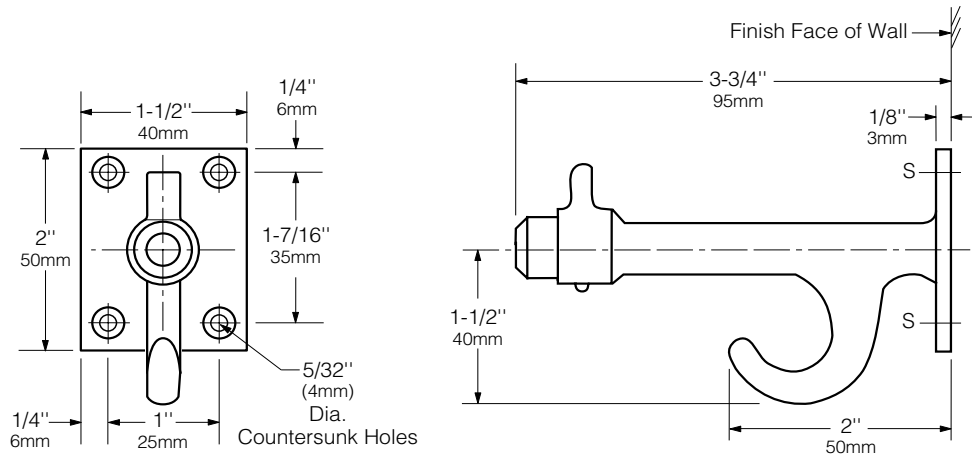

Technical Data

COAT HOOK WITH BUMPER

B-212



MATERIALS:

Hook and Base — Solid cast aluminum with matte finish.

Bumper — Hard rubber secured with drive-screw. Protects wall or partition surfaces.

INSTALLATION:

Mount unit on wall with four screws, furnished by manufacturer, at points indicated by an S. For plaster or dry wall construction, provide concealed backing to comply with local building codes, then secure hook with screws furnished. For other wall surfaces, provide fiber plugs or expansion shields for use with screws furnished, or provide 1/8" (3mm) toggle bolts or expansion bolts.

SPECIFICATION:

Coat hook shall be constructed of solid cast aluminum with matte finish. Unit shall be equipped with hard rubber bumper. Manufacturer's service and parts manual shall be provided to the building owner/manager upon completion of project.

Coat Hook With Bumper shall be Model B-212 of Bobrick Washroom Equipment, Inc., Clifton Park, New York; Jackson, Tennessee; Los Angeles, California; Bobrick Washroom Equipment of Canada Ltd., Scarborough, Ontario; Bobrick Washroom Equipment Pty. Ltd., Australia; and Bobrick Washroom Limited, United Kingdom.